

FMSA/FMGA EMI Input Filters

28 VOLT INPUT - 0.8 AMP

FEATURES

- **Attenuation**
50 dB (FMSA) at 500 kHz
55 dB (FMGA) at 500 kHz
- **Small footprint**
FMSA 0.79 in² (5.1 cm²)
FMGA 0.89 in² (5.7 cm²)
- **Operating temperature -55° to +125°C**
- **Nominal 28 volts input, 0 to 50 volts operation**
- **Up to 0.8 amps throughput current**
- **Compliant to MIL-STD-461C CE-03**
- **Compatible with MIL-STD-704 A-E 28 VDC power bus**

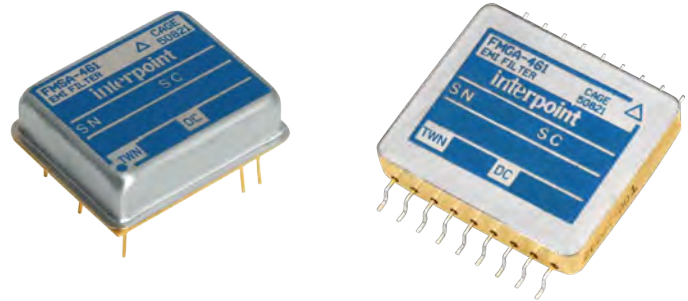

MODELS	
THROUGHPUT CURRENT (A)	
FMSA-461	0.8
FMGA-461	0.8

FMSA SERIES™ EMI FILTER

The Interpoint® FMSA-461 EMI filter modules have been designed as a companion for Interpoint MSA Series™ flyback dc -dc power converters. Multiple MSA power converters can be operated from a single filter provided the total power line current does not exceed the maximum current rating of the filter. The FMSA filter will reduce the MSA's power line reflected ripple current to within the limit of MIL-STD-461C, Method CE03, as shown in the example of Figure 8 on page 9.

The FMSA is fabricated using thick film hybrid technology and is sealed in a metal package for military, aerospace and other applications requiring EMI suppression. See case A1, Figure 15 on page 11 for dimensions. The filter uses only ceramic capacitors for reliable high temperature operation.

OPERATION

The MSA power converter has an internal 2 μ F capacitor across its input power terminals. See Figure 1 on page 2. When the MSA and FMSA filters are used together, this capacitor becomes part of the filter and forms its final LC output section. When 2 or 3 MSAs are used with a single filter, this capacitor becomes 4 μ F or 6 μ F respectively, rather than 2 μ F, improving the rejection vs. frequency.

The FMSA filter can also be used with other types of Interpoint power converters (MHF Series™, MHF+ Series™ and MHE Series™) to comply with CE03. For MHF, MHF+ and MHE models, the converter has an LC type line filter such that an inductor is seen looking into its positive input terminal. For these converters, it is necessary to terminate the filter with a capacitor to insure unconditionally stable operation. A capacitor across the filter output terminals of greater than 4 μ F or the optional damping circuit shown on the connection diagram will be adequate for stable operation. No capacitor is required for the MSA Series models.

OPTIONAL DAMPING CIRCUIT

The optional damping circuit (Figure 2 on page 2) can be used to prevent filter overshoot caused by MIL-STD-704A 80 volt, or other, transients having rise times of less than 200 microseconds. This damping can be alternately provided with a 1.50 Ω resistor in series with the filter's positive input where the additional line loss can be tolerated. For transients with rise times of greater than 200 microseconds, there is no overshoot and the damping circuit is not required.

LAYOUT REQUIREMENTS

The case of the filter must be connected to the case of the converter through a low impedance connection to minimize EMI.

FMSA/FMGA EMI Input Filters

28 VOLT INPUT - 0.8 AMP

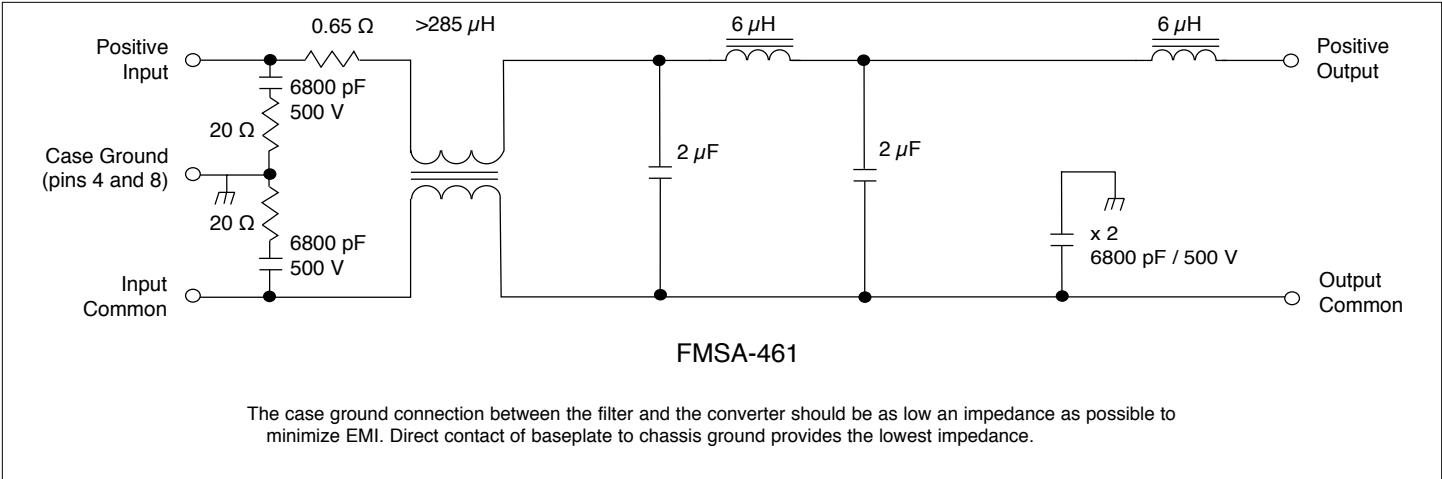

FIGURE 1: FMSA SCHEMATIC – TYPICAL VALUES

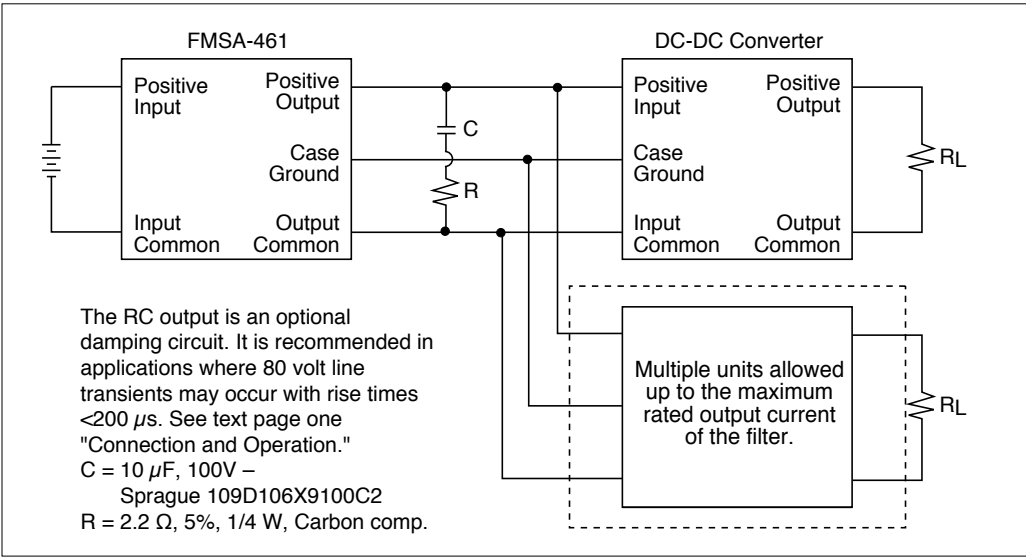

FIGURE 2: FMSA DAMPING CIRCUIT

FMSA/FMGA EMI Input Filters

28 VOLT INPUT - 0.8 AMP

FMGA SERIES™ EMI FILTER

The Interpoint surface mount FMGA-461 EMI filter has been designed to work with Interpoint surface mount MGA Series™ and MGH Series™ dc-dc converters. Multiple MGA or MGH converters can be operated from a single FMGA filter provided the total power line current does not exceed the filter's maximum current rating. The FMGA filter will reduce the converter's power line reflected ripple current to within the limit of MIL-STD-461C, Method CE03 as shown in Figure 10 through Figure 14 on page 10. The filter uses only ceramic capacitors for reliable high-temperature operation.

CONNECTION AND OPERATION

Where more than one pin has the same designation (e.g. pins 7, 8, and 9 are Positive Output), all of those pins must be connected for output performance to meet the specifications.

The MGA Series has an internal 2 μ F capacitor on its input terminals and the MGH Series has an internal 0.47 μ F capacitor across its input power terminals. See Figure 3 on page 4. When the MGA or MGH converters are used with the FMGA filter, this capacitor becomes part of the filter and forms its final LC output section. When 2 or 3 MGA or MGH converters are used with a single filter, this capacitor becomes larger, improving the rejection versus frequency.

TRANSIENT DAMPING

The optional damping circuit shown in Figure 4 on page 4 will prevent filter overshoot caused by 80 volt transients with rise times of less than 200 microseconds. The damping circuit can be used with a 1.50 Ω resistor in series with the filter's positive input where the additional line loss can be tolerated. For transients with rise times of greater than 200 microseconds, there is no overshoot and the damping circuit is not required.

SURFACE MOUNT PACKAGE

The FMGA EMI filter can be surface mounted with pick-and-place equipment or manually. It is recommended that the case be attached with flexible epoxy adhesive or silicone which is thermally conductive (>1 watt /meter/°K).

Internal components are soldered with SN96 (melting temperature 221°C) to prevent damage during reflow. Maximum reflow temperature for surface mounting the FMGA filter is 220°C for a maximum of 30 seconds. SN60, 62, or 63 are the recommended types of solder. Hand soldering should not exceed 300°C for 10 seconds per pin.

The hermetically sealed metal cases are available in two different lead configurations. For case dimensions and options, see Case B, Figure 16 on page 12 and the solder pad layout of Figure 17 on page 12.

LAYOUT REQUIREMENTS

The case of the filter must be connected to the case of the converter through a low impedance connection to minimize EMI.

FMSA/FMGA EMI Input Filters

28 VOLT INPUT - 0.8 AMP

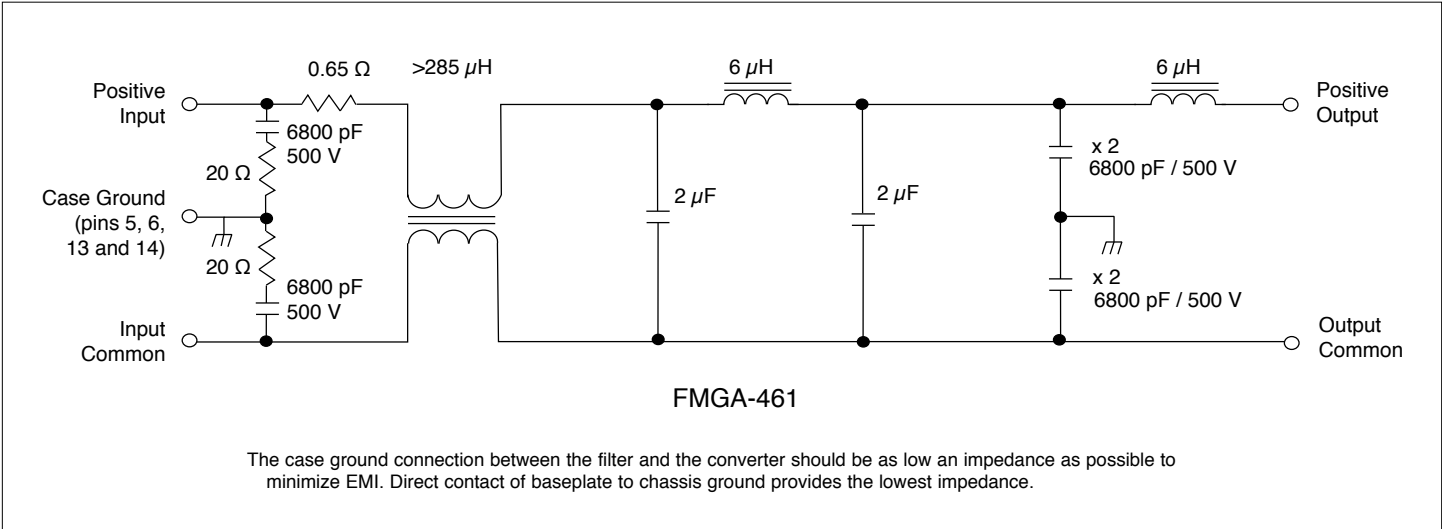

FIGURE 4: FMGA SCHEMATIC – TYPICAL VALUES

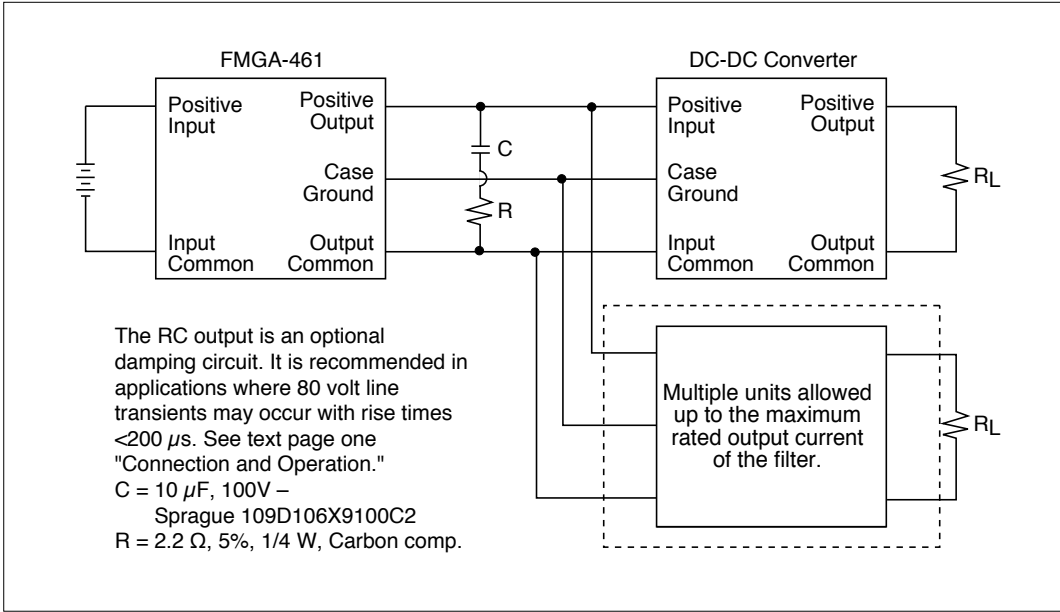

FIGURE 3: FMGA DAMPING CIRCUIT

FMSA/FMGA EMI Input Filters

28 VOLT INPUT - 0.8 AMP

PIN OUT FMSA	
Pin	Designation
1	Positive Input
2, 3	Positive Output
4	Case Ground
5, 6	Output Common
7	Input Common
8	Case Ground

TABLE 1: FMSA PIN OUT

PINS NOT IN USE FMSA	
Case Ground (4)	Connect pin to case for optimum filtering.

TABLE 2: FMSA PINS NOT IN USE

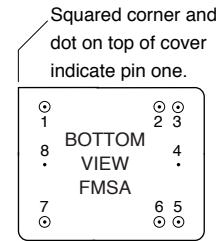

For dimensions, see case A1, Figure 15 on page 11.

FIGURE 5: FMSA PIN OUT

PIN OUT FMGA	
Pin	Designation
1, 2	Positive Input
3, 4	No connection
5, 6	Case Ground
7, 8, 9	Positive Output
10, 11, 12	Output common
13, 14	Case Ground
15, 16	No connection
17, 18	Input Common

To meet specified performance, all pins must be connected except "No Connection" pins.

TABLE 3: FMGA PIN OUT

PINS NOT IN USE FMGA	
Case Ground (5, 6, 13, 14)	Connect pins to case for optimum filtering.
No connection (3, 4, 15, 16)	Connect pins to case for optimum filtering.

TABLE 4: FMGA PINS NOT IN USE

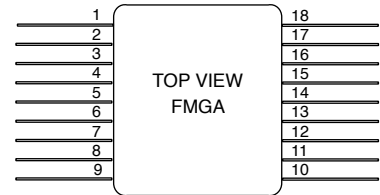

Differently colored glass bead around pin one or dimple in header (bottom or side of case) indicates pin one. Cover marking is oriented with pin one at the upper right corner.

For dimensions and the gull-wing lead option, see case B Figure 16 on page 12. For solder pad layout, see case B, Figure 17 on page 12

FIGURE 6: FMGA PIN OUT

FMSA/FMGA EMI Input Filters

28 VOLT INPUT - 0.8 AMP

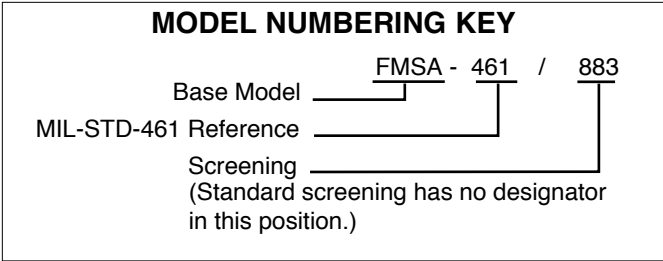

TABLE 5: MODEL NUMBERING KEY

DLA DRAWING NUMBERS	
DLA DRAWING (5915)	FMSA SIMILAR PART
96003-01HXX	FMSA-461/883
For exact specifications for a DLA Drawing product, refer to the DLA Drawing. DLA Drawings can be downloaded from: http://www.landandmaritime.dla.mil/programs/smcr	

TABLE 6: DLA DRAWING NUMBER CROSS REFERENCE

MODEL NUMBER OPTIONS		
TO DETERMINE THE MODEL NUMBER ENTER ONE OPTION FROM EACH CATEGORY IN THE FORM BELOW.		
CATEGORY	Base Model	Screening ¹
OPTIONS	FMSA-461	(standard, leave blank) ES 883
FILL IN FOR MODEL #	FMSA-461	/ _____
Notes 1. Screening: For standard screening leave the screening option blank. For other screening options, insert the desired screening level. For more information see Table 11 on page 20 and Table 12 on page 21.		

TABLE 7: MODEL NUMBER OPTIONS

FMSA/FMGA EMI Input Filters

28 VOLT INPUT - 0.8 AMP

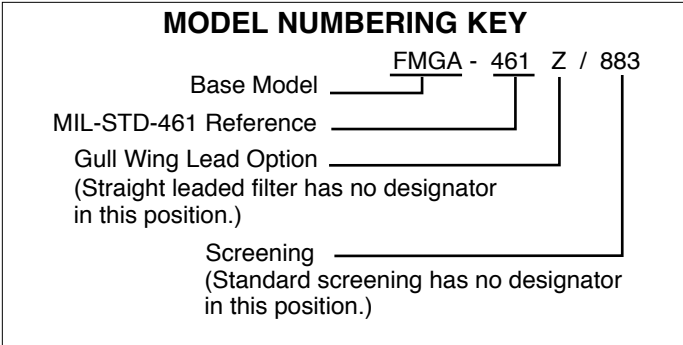

TABLE 8: MODEL NUMBERING KEY

DLA DRAWING NUMBERS	
DLA DRAWING (5915)	FMGA SIMILAR PART
96003-01HYX	FMGA-461/883
96003-01HZA	FMGA-461Z/883
For exact specifications for a DLA Drawing product, refer to the DLA Drawing. DLA Drawings can be downloaded from: http://www.landandmaritime.dla.mil/programs/smcr	

TABLE 9: DLA DRAWING NUMBER CROSS REFERENCE

MODEL NUMBER OPTIONS			
TO DETERMINE THE MODEL NUMBER ENTER ONE OPTION FROM EACH CATEGORY IN THE FORM BELOW.			
CATEGORY	Base Model	Surface Mountable Lead Configuration ¹	Screening ²
OPTIONS	FMGA-461	(standard "flat" case B, leave blank) Z (solder-dipped gull wings)	(standard, leave blank) ES 883
FILL IN FOR MODEL #	FMGA-461	/	_____
Notes 1. Case B, standard "flat" case, does not require a case designator in the model number. Case B with solder-dipped gull wings requires "Z" in the case designator position of the model number. 2. Screening: For standard screening leave the screening option blank. For other screening options, insert the desired screening level. For more information see Table 11 on page 20 and Table 12 on page 21.			

TABLE 10: MODEL NUMBER OPTIONS

FMSA/FMGA EMI Input Filters

28 VOLT INPUT - 0.8 AMP

TABLE 11: OPERATING CONDITIONS, 25°C CASE.

FMSA-461 SERIES / FMGA-461 SERIES		ALL MODELS			UNITS
PARAMETER	CONDITIONS	MIN	TYP	MAX	
LEAD SOLDERING TEMPERATURE ¹	10 seconds max.	—	—	300	°C
STORAGE TEMPERATURE ¹		-65	—	+150	°C
CASE OPERATING TEMPERATURE ^{1, 2}		-55	—	+125	°C
ISOLATION, ANY PIN TO CASE	@ 500 VDC AT 25°C	100	—	—	Megohms

Notes

1. Guaranteed by characterization test and/or analysis. Not a production test.
2. Derate linearly from 100% at 100°C to 0.60 amps at 125°C. Above 125°C derate to 0%.

TABLE 12: ELECTRICAL CHARACTERISTICS: -55 TO +125°C CASE, UNLESS OTHERWISE SPECIFIED.

PARAMETER	CONDITIONS	FMSA-461			FMGA-461			UNITS
		MIN	TYP	MAX	MIN	TYP	MAX	
INPUT VOLTAGE ¹	CONTINUOUS	0	28	50	0	28	50	V
	TRANSIENT 100 ms ¹	—	—	80	—	—	80	V
INPUT CURRENT ^{1, 2}	STEADY STATE	—	—	0.80	—	—	0.80	A
NOISE REJECTION	500 kHz, T _C = 25°C	55	70	—	55	70	—	dB
	500 kHz, T _C = +55 to 125°C	50	70	—	50	70	—	
	1 MHz, T _C = 25°C	54	70	—	54	70	—	
	1 MHz, T _C = +55 to 125°C	50	70	—	50	70	—	
	5 MHz, T _C = 25°C	50	—	—	50	—	—	
	5 MHz, T _C = +55 to 125°C	45	—	—	45	—	—	
COMMON MODE NOISE REJECTION ¹	2 to 50 MHz, T _C = 25°C	40	—	—	40	—	—	dB
DC RESISTANCE (R _{DC})	T _C = 25°C	—	—	1.2	—	—	1.2	Ω
CAPACITANCE	ANY PIN TO CASE T _C = 25°C	22	—	31	36	—	45	nF
OUTPUT VOLTAGE ¹	STEADY STATE	$V_{OUT} = V_{IN} - I_{IN}(R_{DC})$			$V_{OUT} = V_{IN} - I_{IN}(R_{DC})$			V
INTERNAL POWER DISSIPATION ¹	MAXIMUM CURRENT T _C = 25°C	—	—	0.77	—	—	0.77	W

Notes

1. Guaranteed by characterization test and/or analysis. Not a production test.
2. Derate linearly from 100% at 100°C to 0.60 amps at 125°C. Above 125°C derate to 0%.

FMSA/FMGA EMI Input Filters

28 VOLT INPUT - 0.8 AMP

TYPICAL PERFORMANCE PLOTS: 25°C CASE, 28 VIN, 100% LOAD, FREE RUN, UNLESS OTHERWISE SPECIFIED.
FOR REFERENCE ONLY, NOT GUARANTEED SPECIFICATIONS.

FMSA EMI FILTERS

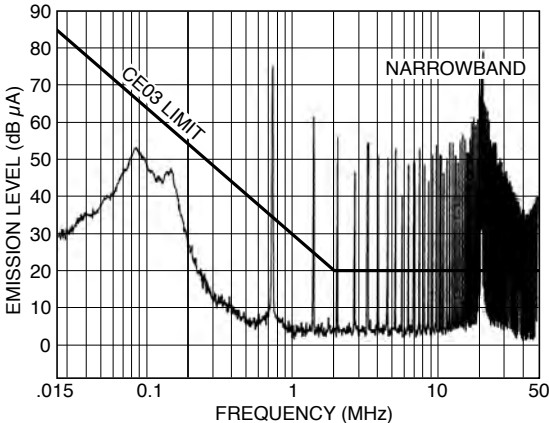

MSA2805S converter without a filter.

FIGURE 7

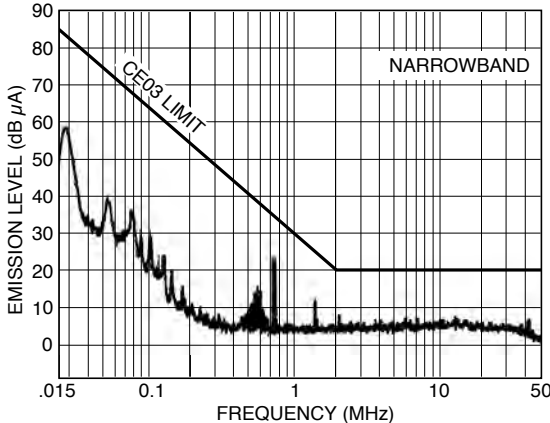

MSA2805S converters at full load with an FMSA-461 EMI filter

FIGURE 8

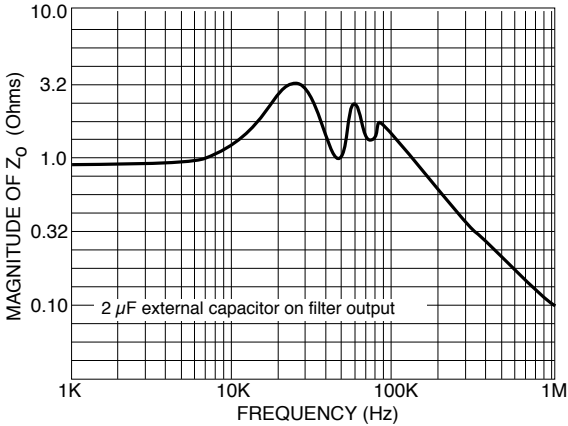

Typical output impedance (Z) with input shorted FMSA-461 EMI filter

FIGURE 9

FMSA/FMGA EMI Input Filters

28 VOLT INPUT - 0.8 AMP

TYPICAL PERFORMANCE PLOTS: 25°C CASE, 28 VIN, 100% LOAD, FREE RUN, UNLESS OTHERWISE SPECIFIED.
FOR REFERENCE ONLY, NOT GUARANTEED SPECIFICATIONS.

FMGA EMI FILTERS

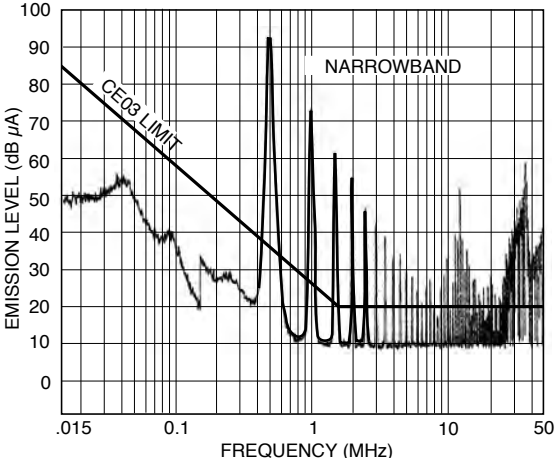

Two MGA2805S converters at full load, no filtering.
Typical power line spectral noise current.

FIGURE 10

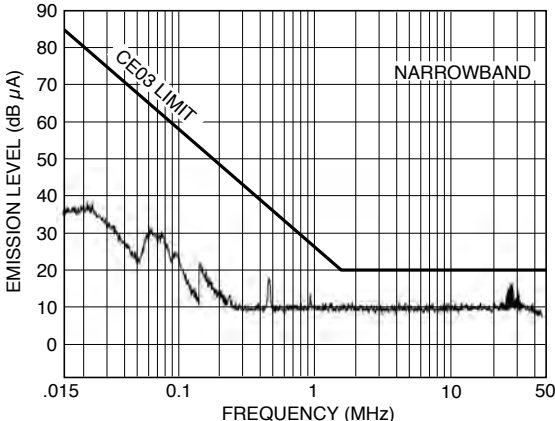

Two MGA2805S converters at full load with FMGA-461 filtering.
Typical power line spectral noise current.

FIGURE 11

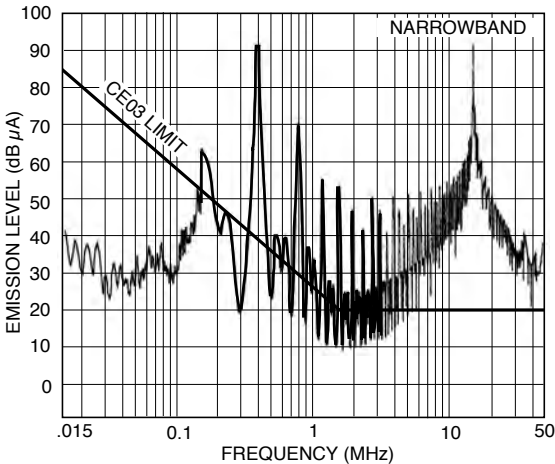

Two MGH2805S converters at full load, no filtering.
Typical power line spectral noise current.

FIGURE 12

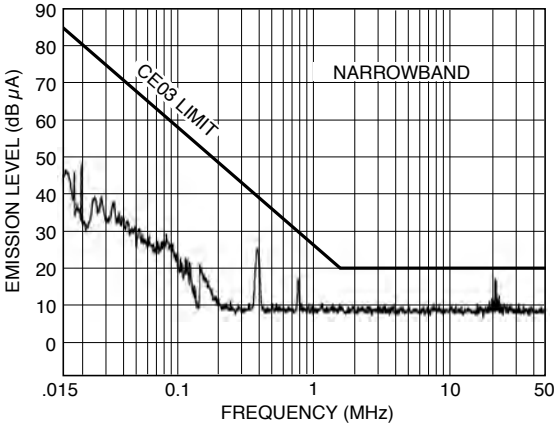

Two MGH2805S converters at full load with FMGA-461 filtering.
Typical power line spectral noise current.

FIGURE 13

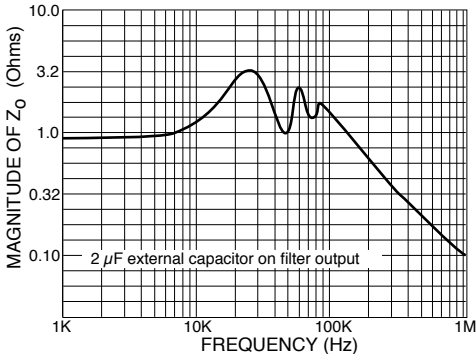

Typical Output Impedance (Z)
With Input Shorted - FMGA

FIGURE 14

FMSA/FMGA EMI Input Filters

28 VOLT INPUT - 0.8 AMP

BOTTOM VIEW CASE A1 FMSA

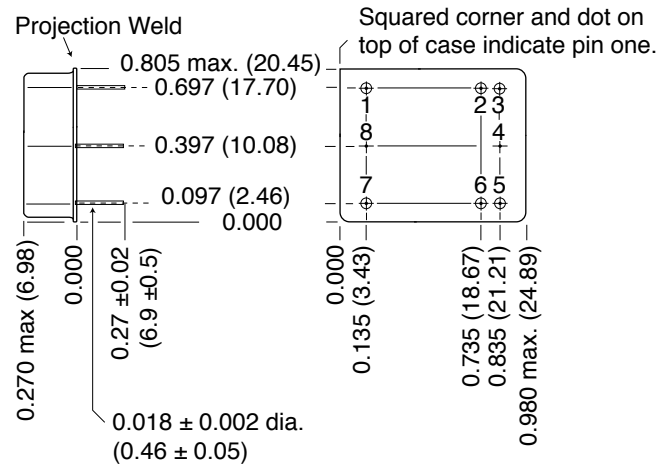

Seal hole: 0.056 ± 0.002 (1.42 ± 0.05)

Weight: 11.5 grams maximum

Case dimensions in inches (mm)

Tolerance ±0.005 (0.13) for three decimal places
 ±0.01 (0.3) for two decimal places
 unless otherwise specified

CAUTION

Heat from reflow or wave soldering may damage the device.
 Solder pins individually with heat application not exceeding 300°C for 10 seconds per pin.

Materials

Header Kovar/Nickel/Gold
 Cover Kovar/Nickel
 Pins Kovar/Nickel/Gold matched glass seal
 Gold plating of 50 microinches minimum

Case A1 FMSA, Rev E, 2015.12.14
 Please refer to the numerical dimensions for accuracy.

FIGURE 15: CASE A1

FMSA/FMGA EMI Input Filters

28 VOLT INPUT - 0.8 AMP

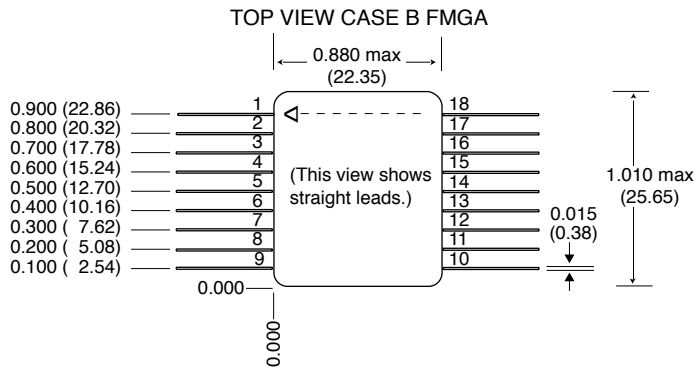

CASE B1 GULL-WING SOLDER PADS FMGA CASE Z

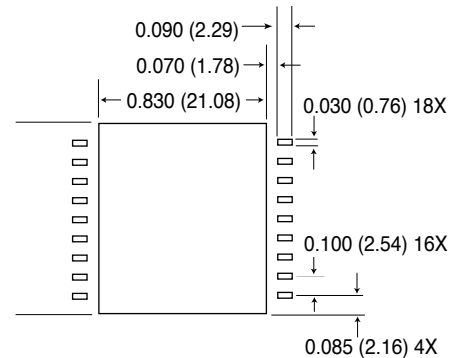

The triangle (ESD) marking on the cover indicates pin one. Cover marking is oriented with pin one at the upper right corner. The straight lead configuration does not require a "case designator" in the model number. ex. FMGA-461

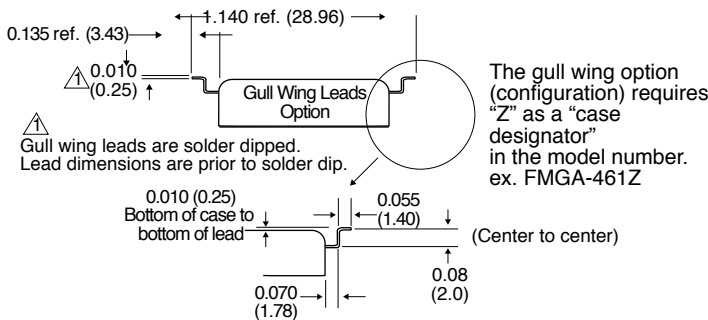
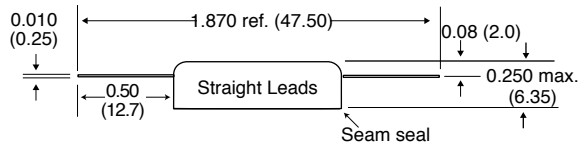

Seal hole: 0.040 ±0.002 (1.02 ±0.05)

Weight: 12 grams maximum

Case dimensions in inches (mm)

Tolerance ±0.005 (0.13) for three decimal places, ±0.01 (0.3) for two decimal places unless otherwise specified. Please refer to the numerical dimensions for accuracy.

CAUTION

Maximum reflow temperature is 220°C for a maximum of 30 seconds. SN60, SN62, or SN63 are the recommended types of solder. See MGH gull-wing solder pad layout. Hand soldering should not exceed 300°C for 10 seconds per pin.

Materials

- Header Kovar/Nickel/Gold
- Cover Kovar/Nickel
- Pins Kovar/Nickel/Gold matched glass seal
- Gold plating of 50 - 150 microinches is included in pin diameter

Case B FMGA, Rev E, 2015.12.09

FIGURE 16: CASE B

Dimensions in inches (mm)

Tolerance ±0.005 (0.13) for three decimal places ±0.01 (0.3) for two decimal places, unless otherwise specified. Please refer to the numerical dimensions for accuracy.

CAUTION:

Internal components are soldered with SN96 (melting temperature 221°C) to prevent damage during reflow. Maximum reflow temperature for surface mounting the FMGA filter is 220°C for a maximum of 30 seconds. SN60, 62, or 63 are the recommended types of solder. Hand soldering should not exceed 300°C for 10 seconds per pin.

SOLDER MASK NOTES

1. Pad dimensions are for the solder mask. Leads common to each other can be connected to each other as desired.
2. Ground (case) pins should be connected to the center pad for improved grounding.
3. Connect "no connection" pins to case ground to reduce EMI.
4. Center pad should not have a solder mask.
5. Adhesive attach is intended to be a surface for soldering the hybrid to the circuit board.
6. Pre-tin base of converter prior to soldering.
7. If less rotation of case is desired, reduce the width of the large case pad by 0.020 inches (0.51 mm). Pad length can be extended 0.010 inches (0.25 mm) towards the case body and an as-desired dimension away from the case body.
8. Do not exceed 220°C as measured on the body of the converter (top or bottom).
9. Attach the body of the case to the board with a thermally conductive adhesive or SN60, 62, or 63 solder. The adhesive can be electrically conductive as well. It can be applied as an underfill post solder or dispensed and cured prior or during solder.
10. In the presence of vibration, to ensure reliable mechanical attachment, the body of the case should be attached with adhesive or solder as noted above (note 7). The leads alone do not provide sufficient mechanical attachment.

Case B1 FMGA Solder Pads, Rev F, 2013.05.31

FIGURE 17: CASE B SOLDER PAD

FMSA/FMGA EMI Input Filters

28 VOLT INPUT - 0.8 AMP

Table is for reference only. See individual Series' datasheets for specific screening.

ELEMENT EVALUATION ¹ HIGH RELIABILITY /883 (CLASS H)

COMPONENT-LEVEL TEST PERFORMED	QML	
	CLASS H /883	
	M/S ²	P ³
Element Electrical	■	■
Visual	■	■
Internal Visual	■	
Final Electrical	■	■
Wire Bond Evaluation	■	■

Notes

1. Element evaluation does not apply to standard and /ES product.
2. M/S = Active components (microcircuit and semiconductor die).
3. P = Passive components, Class H element evaluation. Not applicable to standard and /ES element evaluation.

TABLE 13: ELEMENT EVALUATION

FMSA/FMGA EMI Input Filters

28 VOLT INPUT - 0.8 AMP

Table is for reference only. See individual Series' datasheets for specific screening.

ENVIRONMENTAL SCREENING HIGH RELIABILITY STANDARD, /ES AND /883 (CLASS H)

TEST PERFORMED	NON-QML ¹		QML ²
	STANDARD	/ES	CLASS H /883
Pre-cap Inspection, Method 2017, 2032	■	■	■
Temperature Cycle (10 times)			
Method 1010, Cond. C, -65°C to +150°C, ambient			■
Method 1010, Cond. B, -55°C to +125°C, ambient		■	
Constant Acceleration			
Method 2001, 3000 g			■
Method 2001, 500 g		■	
PIND, Test Method 2020, Cond. A			■ ³
Burn-in Method 1015, +125°C case, typical ⁴			
96 hours		■	
160 hours			■
Final Electrical Test, MIL-PRF-38534, Group A,			
Subgroups 1 through 6, -55°C, +25°C, +125°C case			■
Subgroups 1 and 4, +25°C case	■	■	
Hermeticity Test			
Gross Leak, Cond. C ₁ , fluorocarbon		■	■
Fine Leak, Cond. A ₂ , helium		■	■
Gross Leak, Dip	■		
Final visual inspection, Method 2009	■	■	■

Test methods are referenced to MIL-STD-883 as determined by MIL-PRF-38534.

Notes

- Standard and ES are non-QML products and may not meet all of the requirements of MIL-PRF-38534.
- All processes are QML qualified and performed by certified operators.
- Not required by DLA but performed to assure product quality.
- Burn-in temperature designed to bring the case temperature to +125°C minimum. Burn-in is a powered test.

TABLE 14: ENVIRONMENTAL SCREENING