

# Inrush Current

## INTERPOINT® APPLICATION NOTE

Although the concepts stated are universal, this application note was written specifically for Interpoint products.

In today's applications, high surge currents coming from the dc bus are a concern as the large current spikes may unintentionally trip a fuse on the bus or adversely affect adjacent circuitry. Understanding what generates the high currents and the ways of mitigating that high current is critical for a successful design. Attempting to fix inrush current problems after the design stage may be difficult.

The inrush current phenomenon for a pulse width modulated (PWM) switching power supply can be addressed in three stages. The first involves the charging of the converter's input filter capacitance. The second is the power converter's time profile of the input current which should be controlled by the soft start circuitry which in turn controls the PWM. The third is the charging rate of the output filter and load elements.

### CHARGING THE CONVERTER'S INPUT CAPACITORS

The converter's input power line filter may consist of a capacitor across the power line or, more generally, a single stage or two stage LC differential filter which will generally be under damped. Refer to Figure 1 for a functional example of a forward converter complete with a single stage input line filter. If the input voltage is applied as a step with a rise time of  $1 \mu\text{s}$  or less, the initial inrush current can be 50 amps or more on an unlimited 28 volt power bus or a bus with significant capacitance. This could occur if power were applied with a switch on an aircraft power bus. Where the input filter is only a capacitor, the initial surge current will be a single surge lasting the duration of the input voltage step. Where an under-damped line filter is involved, the initial inrush current will be an exponentially damped sinusoid lasting for as long as a few hundred microseconds. With a stepped input voltage it is likely that the converter's input filter inductor will saturate. If you are modeling the inrush current in SPICE, you will not see the saturation if you assumed a fixed inductance. An increased rise time of the input line voltage will reduce the inrush surge amplitude. Using a ramp voltage with a  $100 \mu\text{s}$  rise time or longer will reduce the surge currents to reasonable limits.

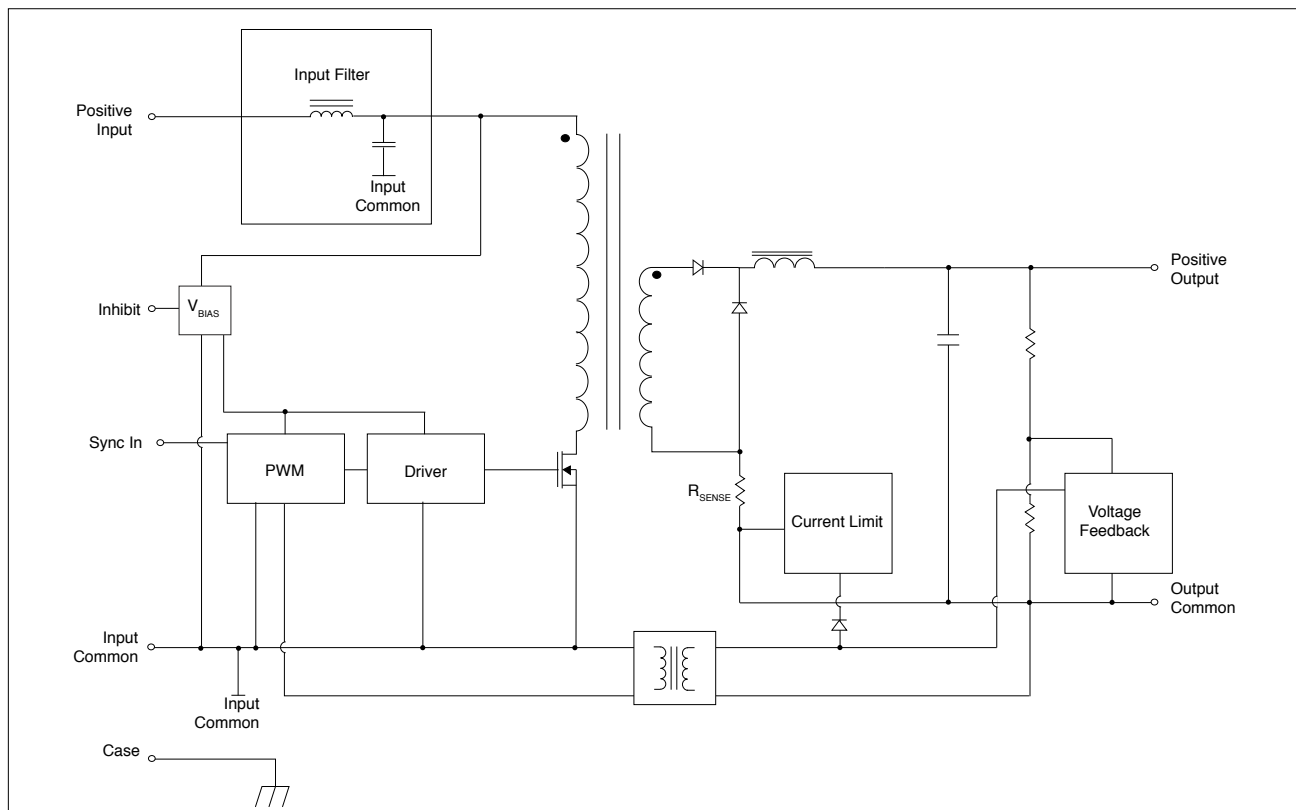

FIGURE 1: FORWARD CONVERTER WITH INPUT LINE FILTER

# Inrush Current

## APPLICATION NOTE

Refer to Figure 2, Figure 3, and Figure 4 for examples of inrush current. Figure 5 illustrates the converter's input filter model used in the examples. For an input capacitor only, the 100  $\mu$ s ramp reduces the surge to less than 10% of that where the rise time is 1  $\mu$ s.

Where a current limited supply is used, beware that starting a single, or several, PWM converters can cause problems with hang-ups and possible damage to the converters due to their negative input impedance characteristic.

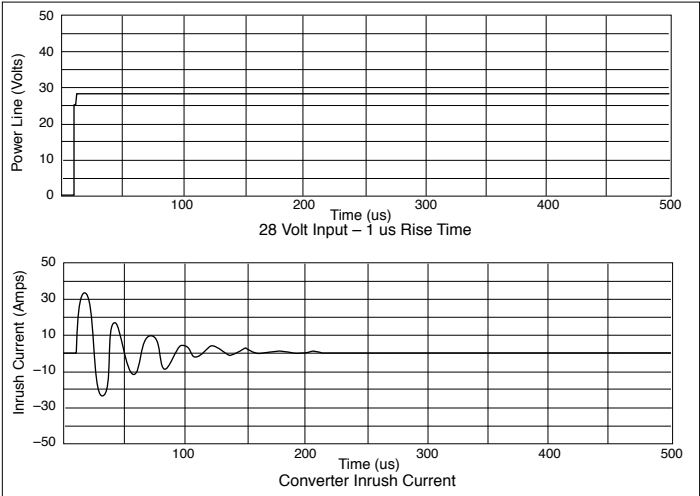

FIGURE 2: 1  $\mu$ s RISE TIME

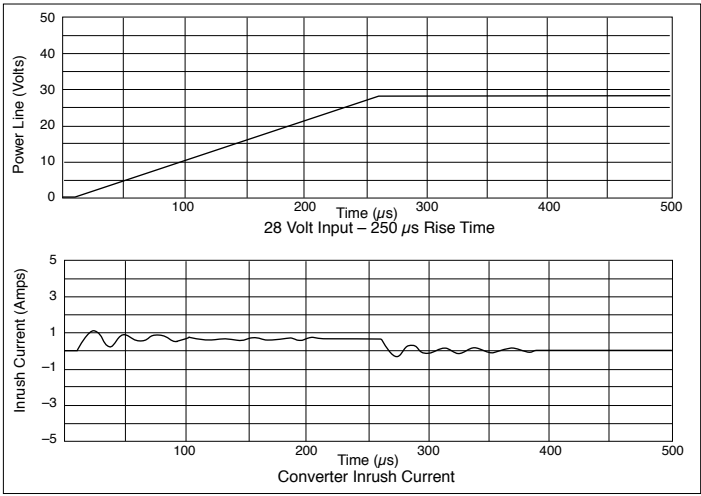

FIGURE 4: 250  $\mu$ s RISE TIME

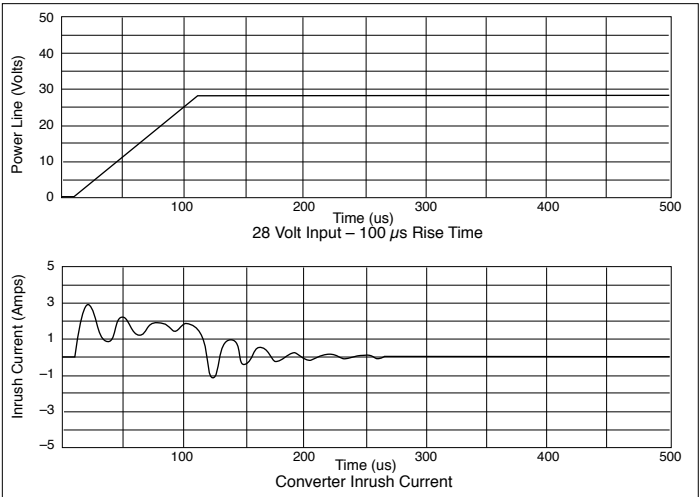

FIGURE 3: 100  $\mu$ s RISE TIME

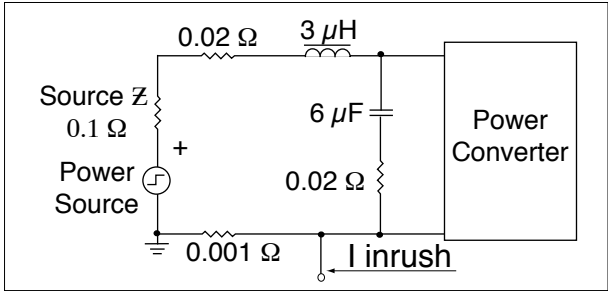

FIGURE 5: INPUT FILTER MODEL

# Inrush Current

## APPLICATION NOTE

### USING AN INRUSH CURRENT LIMITER

Figure 6 shows a simple power ramp circuit that can be used to reduce the inrush current during a fast rising input voltage. Figure 7 shows the simulation of the drain voltage in response to charging a  $6\ \mu\text{F}$  filter capacitor with a step application of the 28 volt power line. The circuit utilizes an N-channel MOSFET in the return line configured as an integrator controlled by a current source.  $D_2$  temperature compensates the  $Q_1$  emitter base junction. The integrator time constant is determined by the voltage across  $R_3$ , approximately 6 volts, and the sum of  $C_2$  and the FET drain gate capacitance. As configured, the voltage across the FET decreases from 28 volts to close to 0 volts in approximately  $100\ \mu\text{s}$ . Actual bench results agree with this fairly well. The transition time will vary with the MOSFET chosen, the value of  $C_1$ , and other component values. Ideally  $C_1$  should be large enough to help swamp out variations in the FET's gate capacitance but also small enough to allow a fast voltage transition. Once timed out, the FET becomes a closed switch, and is full on with its  $R_{ds}$  in series with the 28 volt return line. Alternately, a P-channel FET could be used in the high line with the circuit re-configured to change active component polarities, or an N-channel FET source follower could be used in the high line. The latter has the disadvantage of requiring a charge pump or other means to provide the FET with gate enhancement above the positive 28 volt line. Care should be used in choosing the MOSFET as some of the newer high speed MOSFETS are not meant to work in the linear region. Ideally the voltage transition across the FET should be less than  $400\ \mu\text{s}$  so that the FET is fully on before the converter turns on. If the converter turns on while the MOSFET is in the linear region, there could be an input voltage oscillation which can damage the converter.

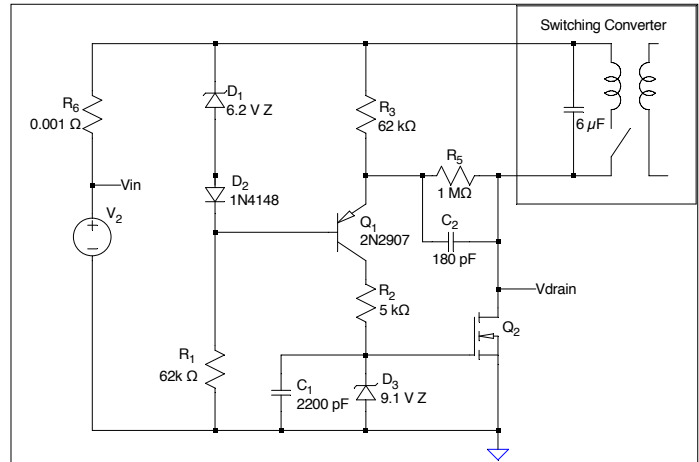

FIGURE 6: CONTROLLED RAMP VOLTAGE STARTING CIRCUIT

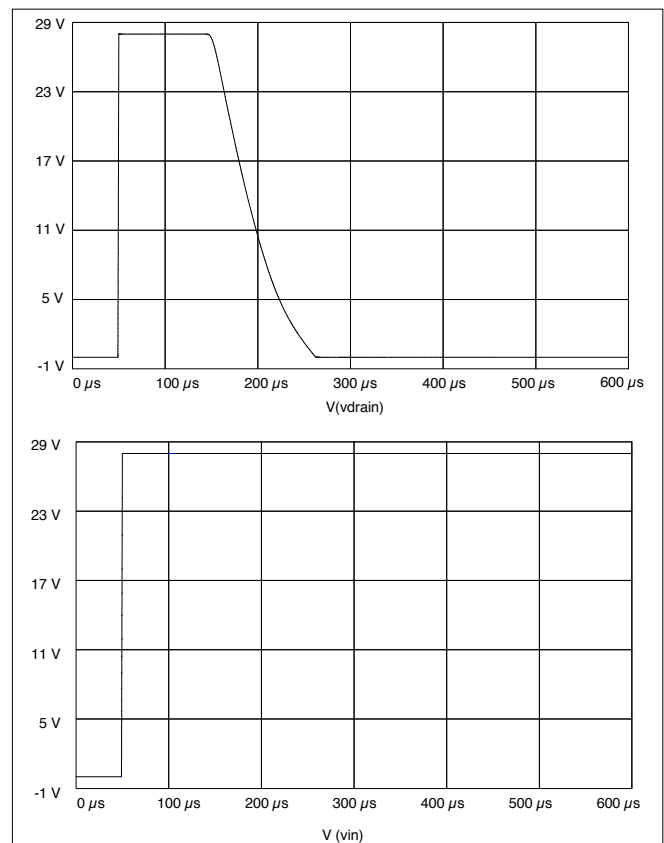

FIGURE 7: SIMULATION RESULTS FROM FIGURE 6

# Inrush Current

## APPLICATION NOTE

### SLOW RISING INPUT VOLTAGE

The input starting current profile of the power converter will follow that of the filter elements by a few hundred microseconds to a few milliseconds, and can last from a few to tens of milliseconds. For a slow rising input voltage, the input current when the PWM begins to control will be on the order of 2.5 times the normal value at 28 volts, and will decline smoothly as the line voltage comes up. This is because of the negative input impedance characteristic where the input line current is inversely proportional to the input line voltage. This means that for constant output power, the product of input voltage and current is constant as a function of line voltage except for small differences in conduction losses over the input range. If a current limited power source is to be used, the limit current must be able to accommodate maximum load and the low line starting voltage, usually 11 to 15 volts for 28 volt devices. Margin should be added in order to avoid oscillation of the input voltage due to the high impedance of a current limited dc source as this can damage a converter. Large inductors at the input of a converter can also create a high resonant impedance which can damage a converter. Where the input line voltage is applied as a step, depending on the individual part and type of soft start, the input current may rise monotonically rather than beginning at a high value and then decreasing as the line voltage rises. Where this is important, it is best to assume the latter case unless the user has proven it to be otherwise.

If the system has a slow rising input voltage, and the higher input currents at low line operation are a concern, the inhibit function can be used to keep the converter off until the input voltage is up and stable. If the input voltage decays at a slow rate during turn off, there could still be high currents due to the low line operation during the decay of input voltage. Multiple converters operating off the same input line can also benefit by using the inhibit function by staggering the turn on time of the individual converters so that the inrush current is spread out over time versus being simultaneous. Using the inhibit function in this manner will also reduce the likelihood of input impedance issues that may occur during the application of input voltage.

### CHARGING THE OUTPUT FILTER

Some examples of output voltage and input current starting profiles are shown below. Figure 8 shows the starting profiles for an MCH2805S flyback converter with current mode control. This part starts at just under 12 volts and has a 0.5 watt load. The efficiency should be about 70% at this load such that the input power will be 0.71 watts. When starting occurs at about 12 volts, the input current will be about 0.06 amps ( $0.71 \text{ W}/12 \text{ V} =$

0.06 A), in agreement with the measured value. At 28 volts, the current decreases to 0.025 amps due to the incrementally negative input impedance. The starting profiles with the load paralleled with  $1000 \mu\text{F}$  is also shown and is well behaved with the current mode control, but requires some additional time to start. Also, due to the large capacitance, there is some overshoot of output voltage. Note that the surge for charging the MCH input filter capacitor has occurred at time zero on the graph and is not shown.

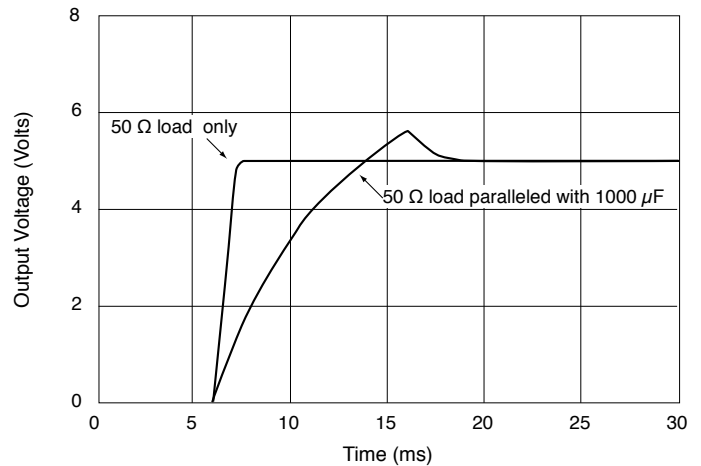
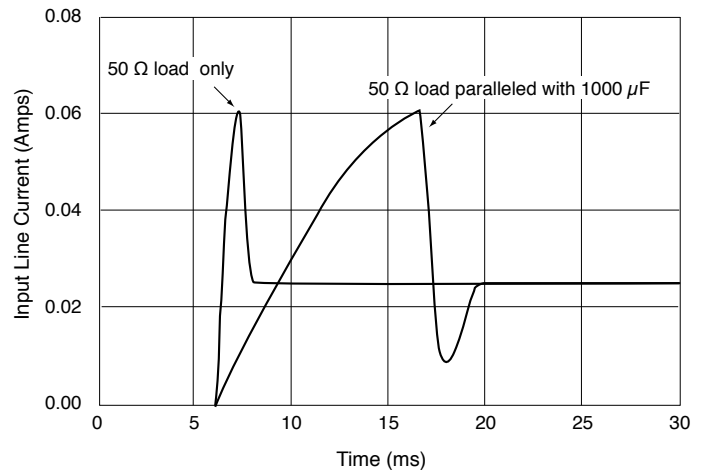

Full Filter Board with  $2 \Omega$  damper. MCH2805S – SN 0081

FIGURE 8: STARTING PROFILE – MCH2805S

# Inrush Current

## APPLICATION NOTE

### POTENTIAL PROBLEMS

Figure 9 shows output voltage and input current waveforms from an MTR2815S converter during the release from inhibit. The same waveforms can be expected from a fast stepped input voltage. The MTR2815S is a 30 watt converter that provides a 15 volt output. The output loading conditions for Figure 9 are 20 ohms resistive (11.25 watts) and 47  $\mu\text{F}$  capacitive. Once inhibit is released the converter's PWM turns on and the output voltage starts to rise. The fast rise of the converter's 15 volt output creates a  $di/dt$  in the converter's output filter capacitor and the 47  $\mu\text{F}$  load capacitance which is in parallel with the 20 ohm load. During the rise of output voltage the converter is providing current to the capacitance and the 20 ohm load. Once the converter's 15 volt output stops rising the  $dv/dt$  is no longer present and current is only being supplied to the 20 ohm load. As can be seen in Figure 9, the current during the rise of the output voltage is almost four times greater than the steady state value of 11.25 watts and the converter may be in, or very close to its current limit value. This is important when calculating the input impedance. Assuming 11.25 watts could be misleading as the MTR's input impedance is approximately four times lower during the rise time of the converter's output voltage than it is during steady state.

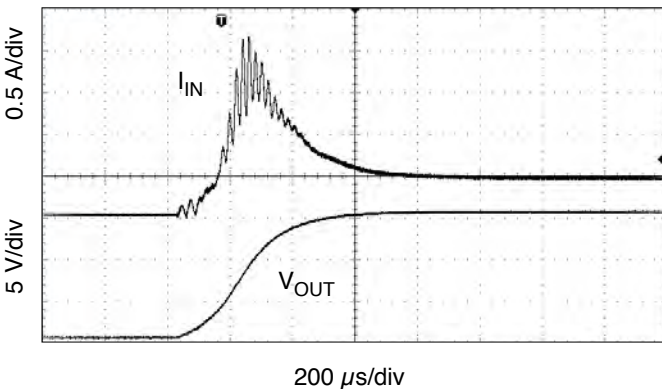

FIGURE 9: STARTING PROFILE – MTR2815S

If you are using Interpoint power converters, make sure the power source is large enough for starting as well as for continuous operation. For starting, the following procedure should work safely.

A) Determine the converter's maximum output power capability in watts. Add a safety factor such as 30%. Multiply by 1.3 to add the safety factor.

B) Divide maximum output power by the decimal efficiency to get the maximum input power. Look for the efficiency curves on the data sheet. If you can't find it, use a figure such as 70%, and divide by 0.7. If you are not sure, contact an Interpoint Application Engineer. [Call +1.425.882.3100 and select option 7 or email [powerapps@crane-eg.com](mailto:powerapps@crane-eg.com)]

C) Now you have the maximum input power. Divide this by the low line voltage at which the PWM starts working to get the maximum input current you will need. You can determine this voltage on the bench by turning the power source voltage up slowly and monitoring the power converter output. If using a bench test, you may want to apply an additional safety factor such as 10%. Do this by multiplying the low line starting voltage by 0.9. Now divide this voltage into the maximum input power you found in step B), and you have the maximum current you will require.

If several power converters are involved, go through the previous procedure on each, and then add the line currents. The answer you get is the minimum current capacity you need from your power source. If you get an answer like 7.5 amps, then the actual line current at 28 volts will be more like 2.6 amps due to the negative input impedance characteristics of the power converters. If you have a supply with an adjustable current limit, be sure to set the limit at 7.5 amps or more, not the 2.6 amp normal line voltage operating current. The lower current limit may cause hang-ups and damage to the converters.